

McDonald's PlayPlace Game

For 2 to 4 Players • Ages 3 & Up

Safety tested for children age 3 and over.

CAUTION: May contain small parts. Not intended for children under 3.

Contents:

Box Platform, Home Board, Spinner Board, Back Board, Ramp, Ladder/Slide Board, Stairway, Tube Tunnel, Wobbly Bridge, 4 Happy Meal® Tokens, Spinner with Snap-in Arrow, 4 Plastic Kid Play Pieces, Sticker Sheet, Rules

Object:

Learn your shapes as you play in the McDonald's® PlayPlace!
Be first to get back home and you're the winner!

Assembly:

STEP 1

Take the Platform (A) out of the Box and remove any components that you find under it. Set the Box Bottom in front of you, making sure the yellow bricks on the side of the Box Bottom are on the right. Put the Platform (A) back into the Box Bottom as shown here, paying attention to the position of the slots.

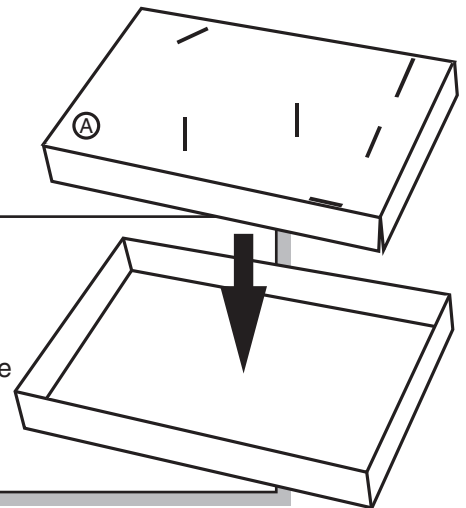

STEP 2

Familiarize yourself with the following parts. Each part (except the Box Bottom) is marked clearly on the back by letter and name:

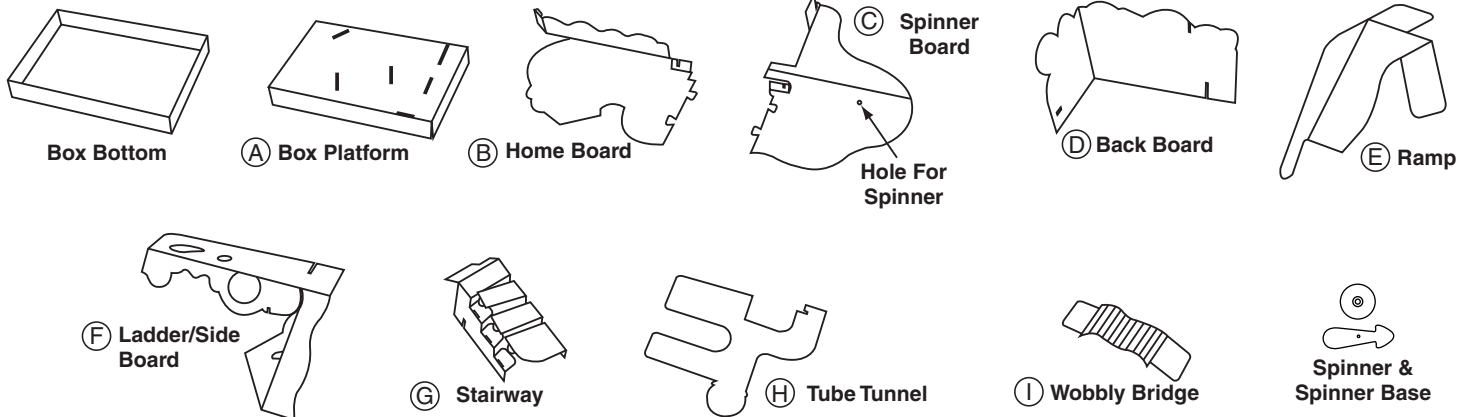

STEP 3

From the underside of the Spinner Board (C), insert the round base through the hole in the cardboard, and then snap the Arrow onto the base from the top.

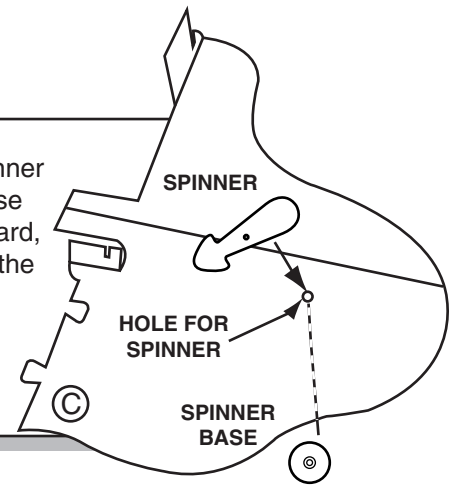

STEP 4

Fold and insert the Back Board (D) so it stands up between the Box Bottom sides and the Platform (A).

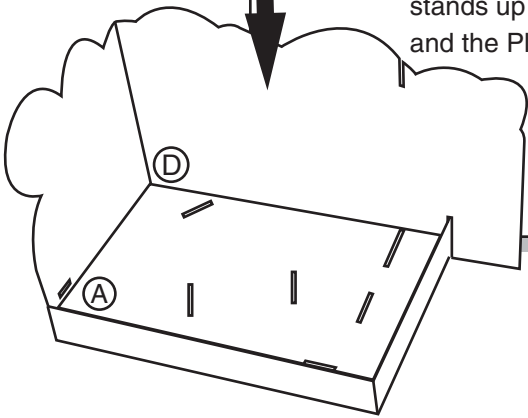

STEP 5

Fold the Home Board (B) as shown and press it up against the front of the Box Bottom. Bend the left side flap around the corner of the box and lock the tab into the slot in the Back Board (D).

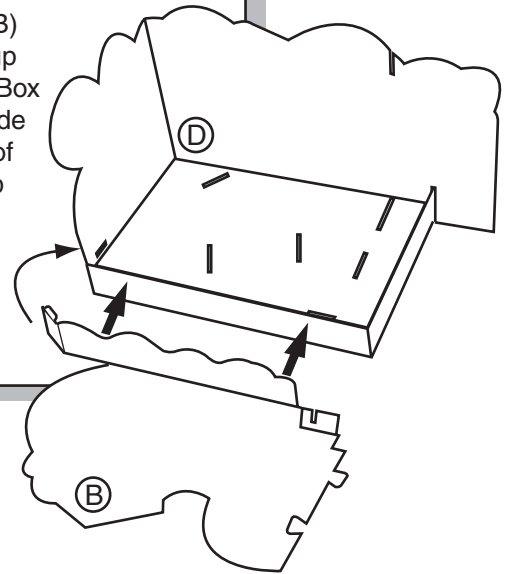

STEP 6

Unfold the Spinner Board (C) as shown and interlock it with the edge of the Home Board (B) like a jigsaw puzzle. Slide the tab at the back edge up into the slot in the Back Board (D).

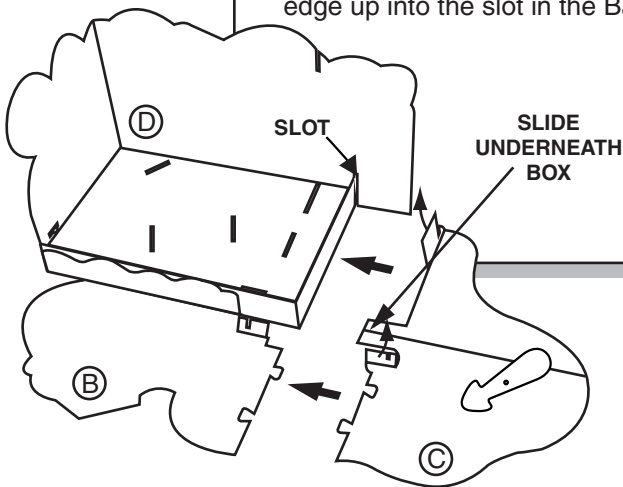

STEP 7

Fold and insert the Ramp (E) so the sides of the Ramp tuck between the Platform (A) and the Back Board (D) and the support goes into the slot in the Platform (A).

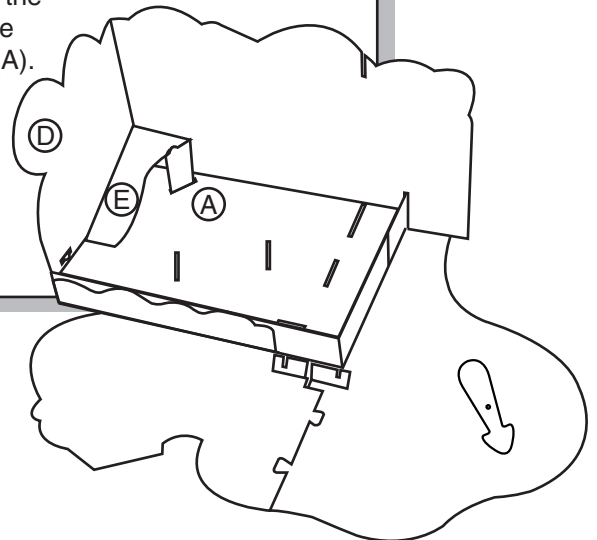

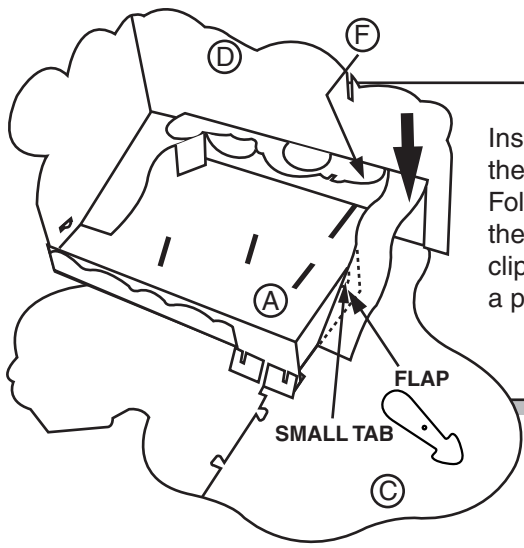

STEP 8

Insert the Ladder/Slide Board (F) between the Back Board (D) and the Platform (A). Fold the Slide down so its flap rests on the Spinner Board (C) and its small tab clips onto the edge of the box bottom like a paper clip.

STEP 9

Lift the flap on the top of the Ladder/Slide Board (F). Insert the Tube Tunnel (H) into the slots on the Platform (A), and put the tab at the top through the slot in the Back Board (D). Slide the Tube Tunnel down to lock the tab in place. Carefully fold the flap of the Ladder/Slide Board (F) down so its slot locks onto the Tube Tunnel (H).

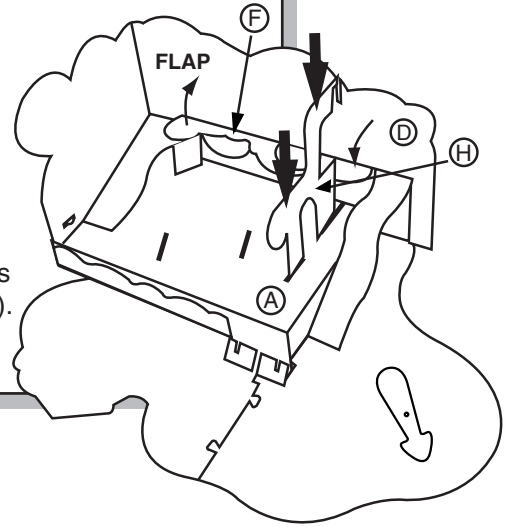

STEP 10

Fold the Stairway (G) as shown and lock the tabs into the slots. Fold the back flap down.

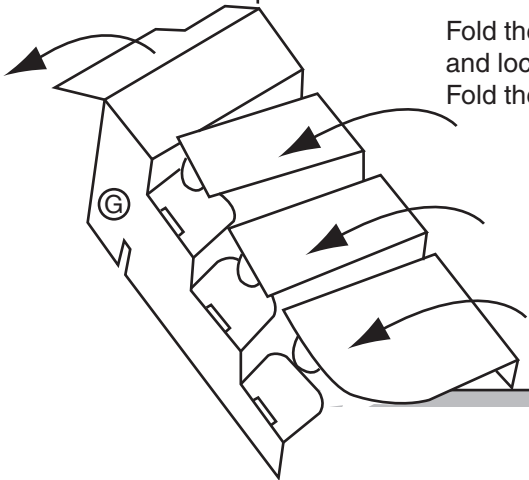

STEP 11

Bend the Wobbly Bridge (I) and insert it into the two remaining slots on the Platform (A).

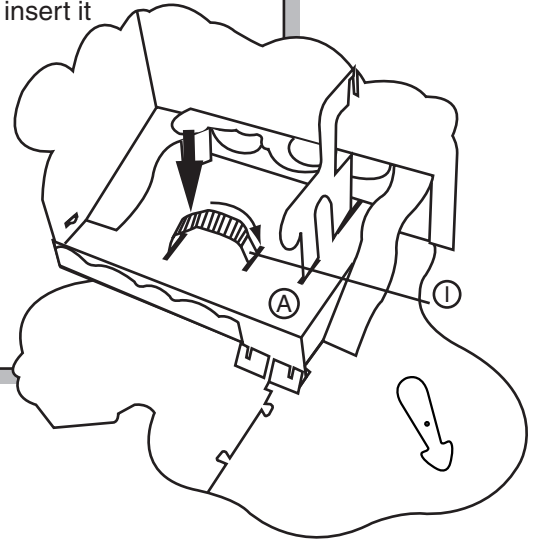

STEP 12

Insert the back flap of the Stairway (G) over the front edge of the Box Bottom and into the slot in the Platform (A). Lock it into the slots on the fold-up tabs on the Home Board (B) and the Spinner Board (C).

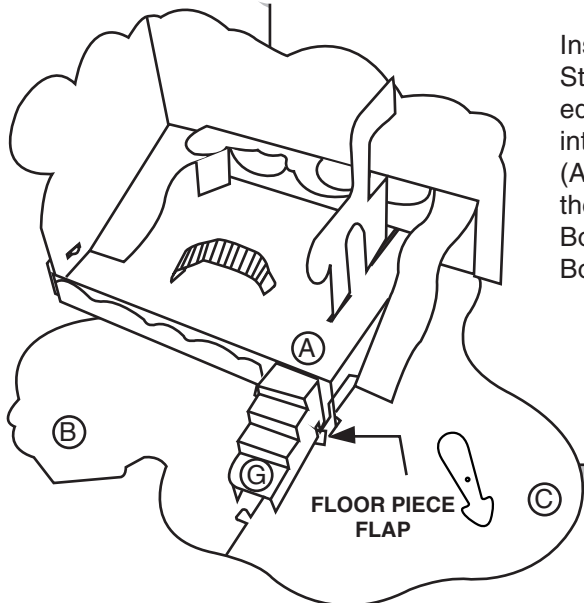

Set Up:

- Punch out the 4 Happy Meal® Tokens and stack them at the bottom of the slide by the shoe shelves.
- Unwrap the Plastic Play Pieces and discard the bags.
- Carefully place the stickers on the fronts and backs of their color-matching Plastic Play Pieces.
- Everybody choose a Kid Play Piece and place it on the house at the start of the game path. Turn your Kid Play Piece so you can see the side where your Kid is wearing shoes.

Play:

Take turns. On your turn, spin the Spinner. Say the name of the shape indicated by the Spinner Arrow, and move your Kid Play Piece up the path to the next space that matches that shape. Then it's the next player's turn.

If you land on a space that has an arrow leading to another space, follow the arrow and stop where it leads you. Sometimes arrows help you get ahead, sometimes they make you fall behind.

If you land on a space that is already occupied, that's okay... the more the merrier!

When you reach the big pink space in front of the shoe shelves, stop there. Turn your Kid Play Piece around so you can see the side where your Kid is wearing socks because you're about to enter the PlayPlace! On your next turn, spin and move toward the Stairway.

Continue to take turns spinning and moving, following the path through the PlayPlace. Walk up the ramp, jump down onto the trampoline, go over the wobbly bridge and climb up the ladder. When you reach the slide, slide to the bottom and stop there. Turn your Kid Play Piece back around to the side that is wearing shoes and take a Happy Meal® Token. On your next turn, spin and move onto the part of the path that goes around the spinner, heading back toward Home.

Winning:

If you're the first player to get through the PlayPlace, get your Happy Meal®, and get back Home, you're the winner!



FREE OF CHARGE
McDonald's
PlayPlace
#4901
©2001

PATCH®

©2001 McDonald's Corporation. McDonald's, and
Happy Meal are trademarks of McDonald's Corporation and
its affiliates. ©2001 Patch Products, Inc. All rights reserved.